

Oil Debris Sensor

Real time condition monitoring for equipment using oil lubrication

The Oil Debris Sensor is designed for use in equipment that uses oil as a lubricant.

Once fitted as a 'smart' sump plug replacement, or within an oil bypass circuit, the sensor uses a powerful magnet to attract ferrous particles suspended within the oil as a result of wear to the internal components. Able to determine between fine and coarse debris, the sensor can also alert or continuously monitor either oil temperature or water* presence.

Installed into a wide variety of fittings and available with either a 0-10V, 4-20mA or CAN digital output.

Typical Applications

- Industrial processes
- Power sector
- Transportation
- Mining

Key Features

- Captures fine and coarse ferrous debris
- Continuous or alert output for water* presence or oil temperature
- Wide operating temperature range
- Choice of 0-10V, 4-20mA or CAN output models
- Suitable for use with oils, fuels and coolants
- Broad range of fittings available
- Calibration software available

Benefits

- Continuous real-time monitoring
- Cost effective high precision measurement sensor
- Separate electronics enclosure for mounting flexibility
- Easy installation in oil sump or bypass line
- Can be user calibrated for optimum performance
- Compliments oil analysis and/or vibration monitoring
- Low cost of ownership

* minimum 10% free water presence



Sensor & electronics



Sensor with debris attached



Optional In-flow adaptor

Oil Debris Sensor

Real time condition monitoring for equipment using oil lubrication

ELECTRICAL			
	Voltage	Current	Digital (CAN)
Supply voltage	6-26V DC	9-26V DC	5-26V DC
Over voltage protection	>32V DC		
Power consumption	<2.9W	<5.6W	<2.8W
Reverse polarity protect'n	To -32V DC		
Analogue resolution	10 bit		
Report rate	10Hz	10Hz	1Hz
Sensor configuration	Accessible via USB (Gill Software)		

MECHANICAL	
Sensor size	57 x Ø24.5mm
Enclosure	55 x 30 x 12mm
Enclosure mounting	2 off M44 clearance holes
Materials (sensor)	Stainless Steel, FEP, PEI
Materials (enclosure)	Aluminium alloy, st/steel, polyester
Sensor/Enclosure cable	26AWG PTFE with DR25 Jacket - 3m /1m
Weight	0.21kg (total)

ENVIRONMENTAL	
Sensor protection	IP66 / IP68
Enclosure protection	IP65
Differential pressure	10 Bar
Sensor operating temp (Enclosure)	-26°C to +150°C (+85°C)
Humidity	95% RH @ +55°C
<small>This product is not designed or certified for use in ATEX environments. Please contact Gill Sensors & Controls for more details</small>	

LIQUIDS	
Fuels	Diesel, gasoline
Oils	Hydraulic, gear, mineral, vegetable, synthetic ester, semi-synthetic, polyalphaolefin, polyalkyleneglycol
Coolants / Other	Ethylene glycol, water, salt water

ORDERING	
Sensor:	Output:
4212—PK - <input type="checkbox"/> <input type="checkbox"/> <input type="checkbox"/>	148 = 4-20mA
	149 = 0-10V
	150 = CAN
Mounting Thread Code:	Thread:
4212—PK - <input type="checkbox"/> <input type="checkbox"/> <input type="checkbox"/>	504 = M22x1.5
	507 = M24x2.0
	552 = 3/4"x16UNF
Inflow Kit 1" = 4212-00-160-100	Inflow Adaptor = 4212-00-161
Inflow Kit 1.5" = 4212-00-160-150	Conduit Kit = 4212-10-051-X

ANALOGUE OUTPUT (Configurable)		
	Voltage	Current
Channel 1 (Fine)	0.25—10V DC	4mA—20mA
Channel 2 (Coarse)	0.25—10V DC	4mA—20mA
Channel 3 (Water/temp)	0.25—10V DC	4mA—20mA
Error Indication	<0.25—10V DC	1mA—20mA

DIGITAL OUTPUT	
J1939 data length	8 bytes
PGN	130816
Byte 0	Coarse measurement %, no scaling Value 255—optional output inhibited during calibration
Byte 1	Fine measurement %, no scaling Value 255—optional output inhibited during calibration
Byte 2	8 Status bits
	Bit 0—High/low temp exceeded
	Bit 1—Oil upper threshold exceeded
	Bit 2—Oil lower threshold exceeded
	Bit 3—Fine measurement error
	Bit 4—Coarse measurement error
	Bit 5—Oil measurement error
	Bit 6—Internal temp sensor error
	Bit 7—External temp sensor error
Byte 3-7	Manufacturer use

MOUNTING THREADS (Contact Gill for other fittings)	
Thread Code	Thread Size
4212-PK-502	M20 x 1.5
4212-PK-504	M22 x 1.5
4212-PK-507	M24 x 2.0
4212-PK-533	1/2" BSPP
4212-PK-552	3/4" - 16 UNF
4212-PK-571	1/2" NPT
4212-PK-573	3/4" NPT
4212-PK-575	1" NPT
4212-PK-576	1 1/4" NPT
4212-PK-577	1 1/2" NPT

Oil Debris Sensor

Real time condition monitoring for equipment using oil lubrication

DIMENSIONS

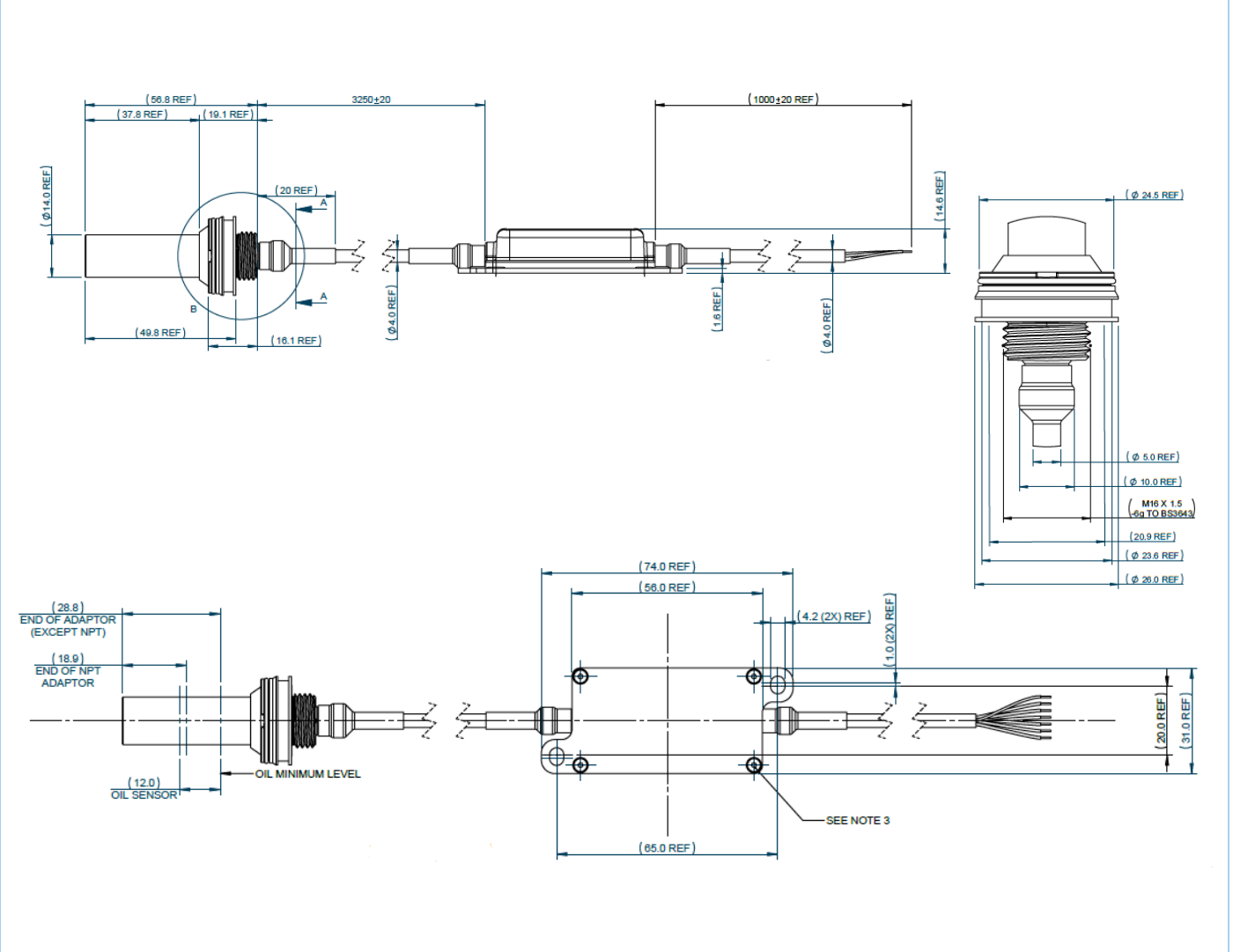

MOUNTING THREADS (4212-PK-...see below)

Thread Code	Thread Size	Insert Depth	Spanner A/F	Torque ± 10%
502	M20 x 1.5	37.05	36.0	50 Nm
504	M22 x 1.5	37.05	36.0	50 Nm
507	M24 x 2.0	37.05	36.0	50 Nm
533	1/2" BSPP	36.55	36.0	50 Nm
552	3/4" x 16 UNF	36.55	36.0	50 Nm

MOUNTING THREADS (4212-PK-...see below)

Thread Code	Thread Size	Insert Depth	Spanner A/F	Torque ± 10%
571	1/2" NPT	32.46	36.0	Refer ANSI / ASME B.20.1
573	3/4" NPT	32.76	36.0	
575	1" NPT	36.24	36.0	
576	1 1/4" NPT	36.85	36.0	
577	1 1/2" NPT	37.28	36.0	

For more information about the WearDetect Oil Debris Sensor please contact Gill Sensors & Controls.

gillsc.com

© 2022 Gill Sensors & Controls Limited

GILL

Designed and manufactured in the UK by Gill Sensors & Controls Limited.