



Model 682C03

ICP® VIBRATION TRANSMITTER

Installation and Operating Manual

**For assistance with the operation of this product,
contact the PCB Piezotronics, Inc.**

Toll-free: 800-959-4464

24-hour SensorLine: 716-684-0001

Fax: 716-684-3823

E-mail: imi@pcb.com

Web: www.imi-sensors.com



Repair and Maintenance

PCB guarantees Total Customer Satisfaction through its “Lifetime Warranty Plus” on all Platinum Stock Products sold by PCB and through its limited warranties on all other PCB Stock, Standard and Special products. Due to the sophisticated nature of our sensors and associated instrumentation, **field servicing and repair is not recommended and, if attempted, will void the factory warranty.**

Beyond routine calibration and battery replacements where applicable, our products require no user maintenance. Clean electrical connectors, housings, and mounting surfaces with solutions and techniques that will not harm the material of construction. Observe caution when using liquids near devices that are not hermetically sealed. Such devices should only be wiped with a dampened cloth—never saturated or submerged.

In the event that equipment becomes damaged or ceases to operate, our Application Engineers are here to support your troubleshooting efforts 24 hours a day, 7 days a week. Call or email with model and serial number as well as a brief description of the problem.

Calibration

Routine calibration of sensors and associated instrumentation is necessary to maintain measurement accuracy. We recommend calibrating on an annual basis, after exposure to any extreme environmental influence, or prior to any critical test.

PCB Piezotronics is an ISO-9001 certified company whose calibration services are accredited by A2LA to ISO/IEC 17025, with full traceability to SI through N.I.S.T. In addition to our standard calibration services, we also offer specialized tests, including: sensitivity at elevated or cryogenic temperatures, phase response, extended high or low frequency response, extended range, leak testing, hydrostatic pressure testing, and others. For more information, contact your local PCB Piezotronics distributor, sales representative, or factory customer service representative.

Returning Equipment

If factory repair is required, our representatives will provide you with a Return Material Authorization (RMA) number, which we use to reference any information you have already provided and expedite the repair process. This number should be clearly marked on the outside of all returned package(s) and on any packing list(s) accompanying the shipment.

Contact Information

PCB Piezotronics, Inc.
3425 Walden Ave.
Depew, NY14043 USA
Toll-free: (800) 828-8840
24-hour SensorLine: (716) 684-0001
General inquiries: info@pcb.com
Repair inquiries: rma@pcb.com

For a complete list of distributors, global offices and sales representatives, visit our website, www.pcb.com.

Safety Considerations

This product is intended for use by qualified personnel who recognize shock hazards and are familiar with the precautions required to avoid injury. While our equipment is designed with user safety in mind, the protection provided by the equipment may be impaired if equipment is used in a manner not specified by this manual.

Discontinue use and contact our 24-Hour Sensorline if:

- Assistance is needed to safely operate equipment
- Damage is visible or suspected
- Equipment fails or malfunctions

For complete equipment ratings, refer to the enclosed specification sheet for your product.

Definition of Terms and Symbols

The following symbols may be used in this manual:



DANGER

Indicates an immediate hazardous situation, which, if not avoided, may result in death or serious injury.

**CAUTION**

Refers to hazards that could damage the instrument.

**NOTE**

Indicates tips, recommendations and important information. The notes simplify processes and contain additional information on particular operating steps.

The following symbols may be found on the equipment described in this manual:



This symbol on the unit indicates that high voltage may be present. Use standard safety precautions to avoid personal contact with this voltage.



This symbol on the unit indicates that the user should refer to the operating instructions located in the manual.



This symbol indicates safety, earth ground.



PCB工业监视和测量设备 - 中国RoHS2公布表

PCB Industrial Monitoring and Measuring Equipment - China RoHS 2 Disclosure Table

部件名称	有害物质					
	铅 (Pb)	汞 (Hg)	镉 (Cd)	六价铬 (Cr(VI))	多溴联苯 (PBB)	多溴二苯醚 (PBDE)
住房	0	0	0	0	0	0
PCB板	X	0	0	0	0	0
电气连接器	0	0	0	0	0	0
压电晶体	X	0	0	0	0	0
环氧	0	0	0	0	0	0
铁氟龙	0	0	0	0	0	0
电子	0	0	0	0	0	0
厚膜基板	0	0	X	0	0	0
电线	0	0	0	0	0	0
电缆	X	0	0	0	0	0
塑料	0	0	0	0	0	0
焊接	X	0	0	0	0	0
铜合金/黄铜	X	0	0	0	0	0
本表格依据 SJ/T 11364 的规定编制。						
0：表示该有害物质在该部件所有均质材料中的含量均在 GB/T 26572 规定的限量要求以下。						
X：表示该有害物质至少在该部件的某一均质材料中的含量超出 GB/T 26572 规定的限量要求。						
铅是欧洲RoHS指令2011/65/ EU附件三和附件四目前由于允许的豁免。						

CHINA RoHS COMPLIANCE

Component Name	Hazardous Substances					
	Lead (Pb)	Mercury (Hg)	Cadmium (Cd)	Chromium VI Compounds (Cr(VI))	Polybrominated Biphenyls (PBB)	Polybrominated Diphenyl Ethers (PBDE)
Housing	O	O	O	O	O	O
PCB Board	X	O	O	O	O	O
Electrical Connectors	O	O	O	O	O	O
Piezoelectric Crystals	X	O	O	O	O	O
Epoxy	O	O	O	O	O	O
Teflon	O	O	O	O	O	O
Electronics	O	O	O	O	O	O
Thick Film Substrate	O	O	X	O	O	O
Wires	O	O	O	O	O	O
Cables	X	O	O	O	O	O
Plastic	O	O	O	O	O	O
Solder	X	O	O	O	O	O
Copper Alloy/Brass	X	O	O	O	O	O

This table is prepared in accordance with the provisions of SJ/T 11364.

O: Indicates that said hazardous substance contained in all of the homogeneous materials for this part is below the limit requirement of GB/T 26572.

X: Indicates that said hazardous substance contained in at least one of the homogeneous materials for this part is above the limit requirement of GB/T 26572.

Lead is present due to allowed exemption in Annex III or Annex IV of the European RoHS Directive 2011/65/EU.

682 Series 4-20mA Din Rail ICP[®] Signal Conditioner



Operating Guide with Enclosed Warranty Information

3425 Walden Avenue, Depew, New York 14043-2495

Phone (716) 684-0003

Fax (716) 684-3823

Toll Free Line 1-800-959-4IMI

MANUAL NUMBER: 60419
MANUAL REVISION: **B**
ECN NUMBER: **46422**

Table of Contents

<i>Introduction.....</i>	<i>Page 3</i>
Block diagram.....	<i>Page 3</i>
<i>General Features.....</i>	<i>Page 4</i>
<i>Installation and Wiring</i>	<i>Page 5</i>
<i>Configuring the 682BX3</i>	<i>Page 9</i>
<i>ESD Sensitivity.....</i>	<i>Page 12</i>
<i>Ordering Information</i>	<i>Page 13</i>

Warranty/Service

<i>Warranty, Service & Return Procedure</i>	<i>Page 14</i>
<i>Customer Service.....</i>	<i>Page 15</i>

Introduction

The 682 Series is a 4-20mA Din Rail Signal Conditioner designed to interface with IMI Sensor's ICP® Accelerometer. Acceleration, Velocity, or Displacement can be converted to a 4-20mA signal by simple DIP Switch selection internal to the Din Rail enclosure. An additional standard feature of the 682 Series is the ability to convert the temperature output from an accelerometer (when equipped) to 4-20mA. Signal Filtering can be easily configured in the field by installing factory calibrated Filter Modules into sockets located inside the enclosure.

Block Diagram

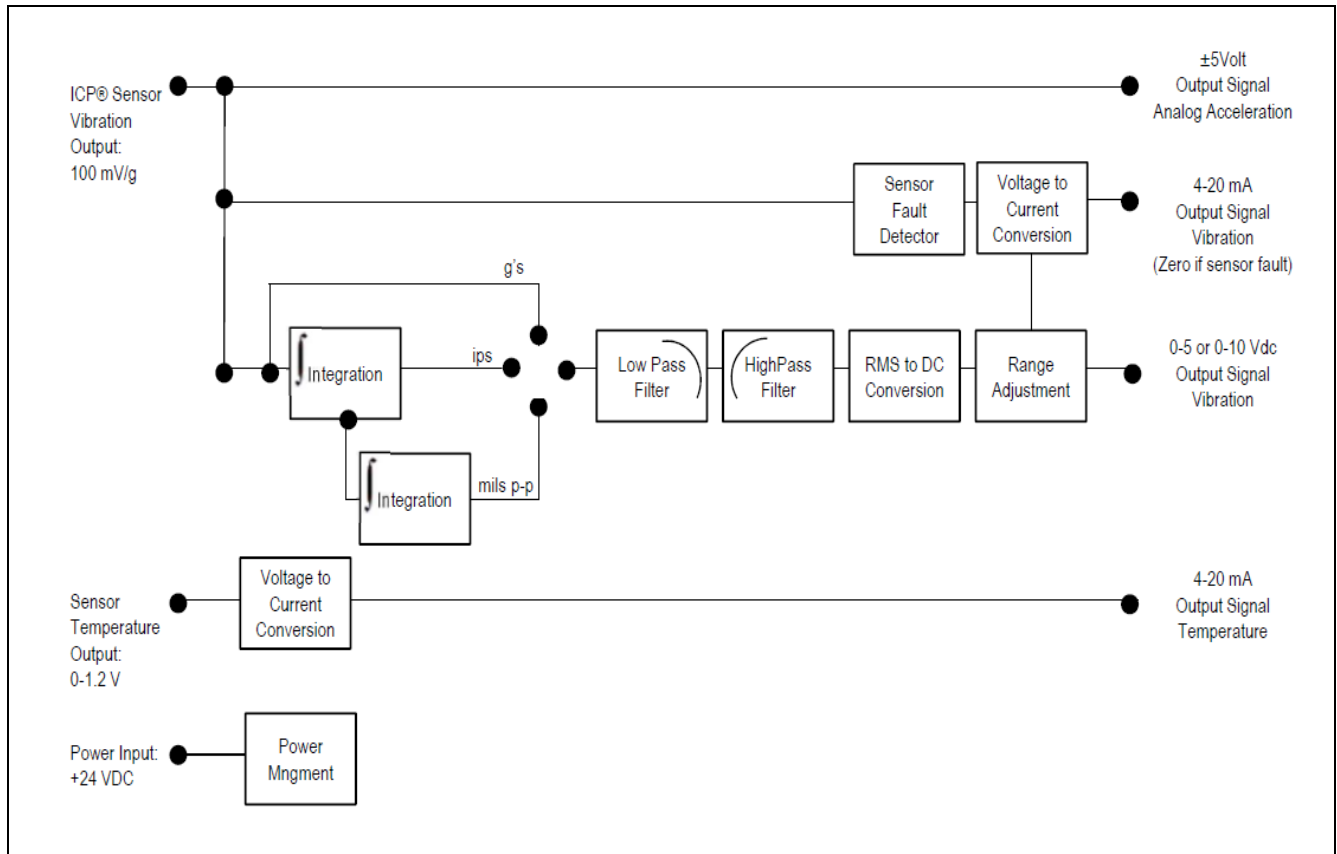

General Features

- External transmitters, signal conditioners, and ICP[®] power supplies can be eliminated by direct connection of the sensor to the Din Rail Signal Conditioner.
- Optional 500Vdc Input to Output Electrical Isolation.
- Selectable 24Vdc Unregulated, 18Vdc regulated, 4mA excitation to power sensor
- 4-20mA Output Signals for Vibration and Temperature.
- Selectable 0-5 or 0-10Vdc Output Signal for Vibration.
- Internal DIP switch selectable vibration ranges include:

Acceleration (g's)	Velocity (in/sec)	Displacement (mils p-p)
5.00	0.50	10.0
10.00	1.00	20.0
20.00	2.00	40.0

- Internal DIP switch selection for Peak or RMS.
- Utilization of Filter Modules for field configuration of High and Low pass 2-pole filtering.
- Analog output signal connections (RV) for conducting frequency analysis and machinery diagnostics.
- LED indicators for Power, Sensor Fault, Acceleration, Velocity, and Displacement.
- Electronic Sensor Fault Indication via 4-20mA output by providing a 0mA signal.
- Configurable for ICP[®] Sensor Power disable to accommodate existing applications.
- Removable Terminal Blocks for easy wiring.
- 35mm (1.38in.) Din Rail Mount configuration.
- Space saving 22.5mm (0.9in.) wide design.

Installation and Wiring

Installation

The 682 Series is designed to be mounted on a 35mm Din Rail. Do not install in a harsh area where it can be exposed to cleaning fluids or machine oils. IMI Sensors recommends mounting the 682BX3 in a type NEMA 4 enclosure to protect the electronics from contamination.

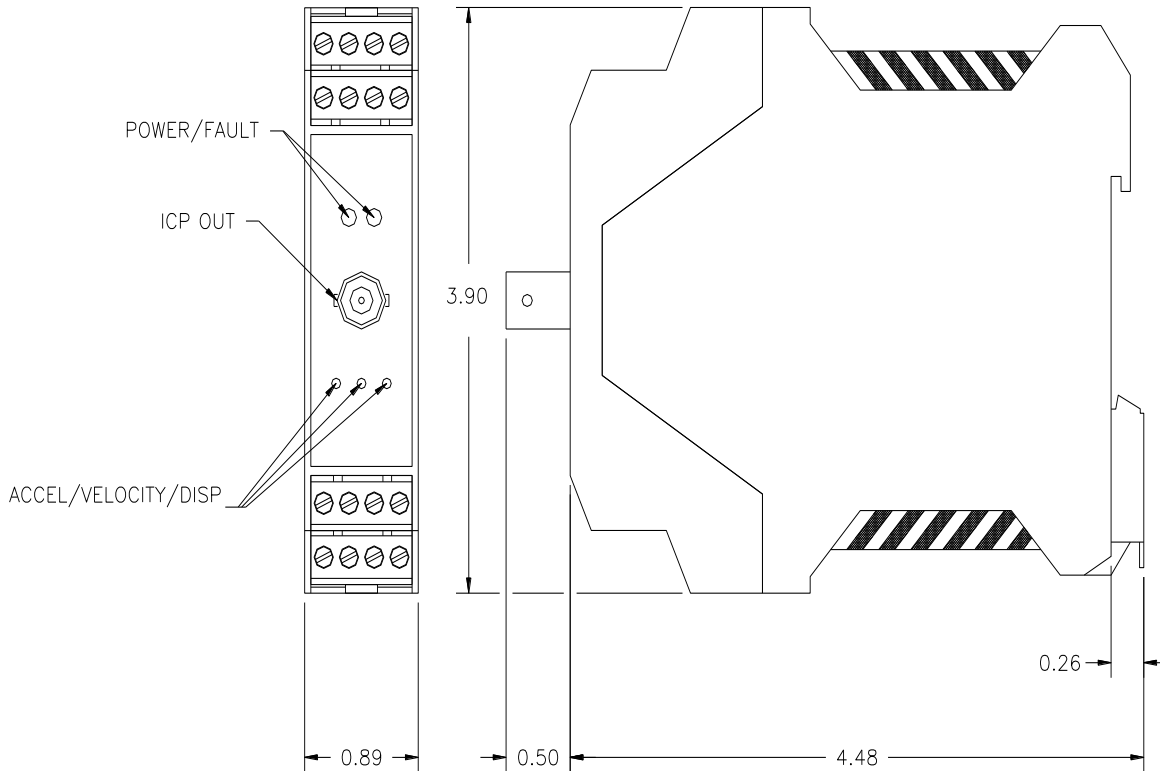

Dimension Drawing

The Power LED is Green which turns on when the unit is powered. The Fault LED is red which turns on when the sensor input is either open or shorted. The Acceleration, Velocity, and Displacement LED is Green which turns on when the corresponding dip switches shown on page 8 are set.

Connector and Pinout Diagram

The 682 Series uses plug-in type screw terminal connectors for all input and output connections.

Strip off 8mm of insulation from the connection wire ends. Using a screwdriver, remove the terminal block from the enclosure in either the up or down direction, terminate the wire in the correct location. Do not exceed a torque of 0.5Nm. Re-install the terminal block.

This easy to assemble connection method allows devices to be exchanged easily and the electrical connection to be visibly isolated.

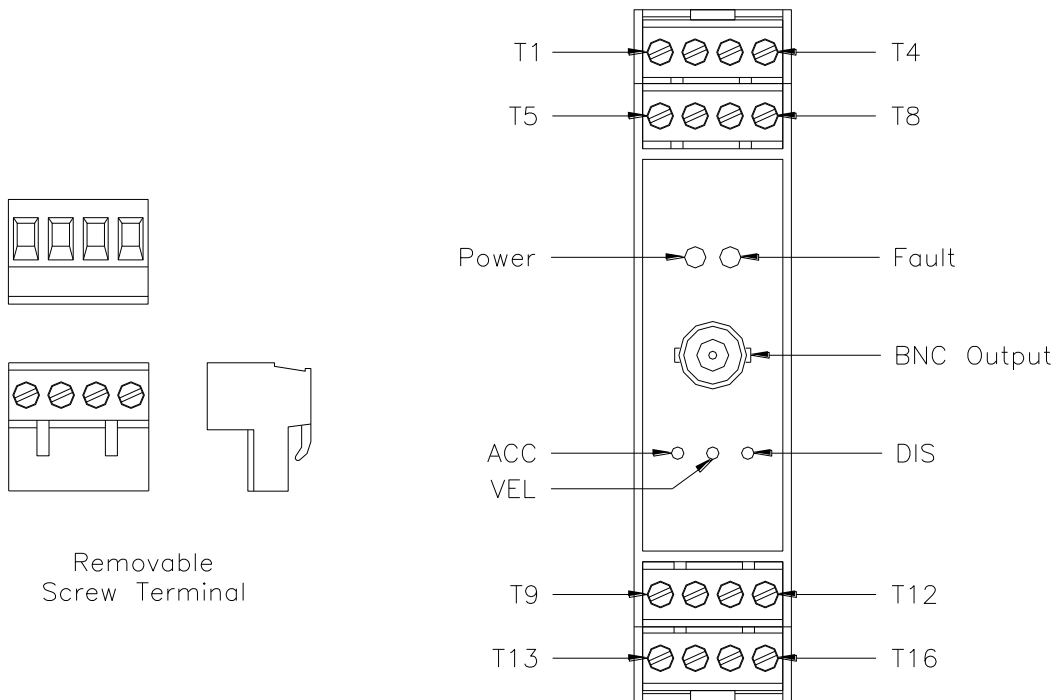

Pin Location Diagram



WARNING

AC and DC input signals and power supply voltages could be hazardous. DO NOT connect live wires to screw terminal plugs, and DO NOT insert, remove, or handle screw terminal plugs with live wires connected.

Pin Descriptions:

DC Power – Pins 1 to 3:

- Pin 1** +Power
- Pin 2** -Power/Common
- Pin 3** Earth Ground

ICP[®] Accelerometer – Pins 4 to 6:

- Pin 4** Shield
- Pin 5** + ICP[®] Accelerometer
- Pin 6** - ICP[®] Accelerometer

Temperature Sensor – Pins 7 to 8:

- Pin 7** + Temperature Sensor
- Pin 8** - Temperature Sensor (- ICP[®] Accelerometer)

Raw Vibration (RV) – Pins 9 to 10, and BNC Jack:

- Pin 9** + RV
- Pin 10** - RV

4 to 20mA Temperature Output – Pins 11 to 12:

- Pin 11** + 4 to 20mA Temperature Output
- Pin 12** - 4 to 20mA Temperature Output

4 to 20mA Vibration Output – Pins 13 to 14:

- Pin 13** + 4 to 20mA Vibration Output
- Pin 14** - 4 to 20mA Vibration Output

0-5/10Vdc Vibration Output – Pins 15 to 16:

- Pin 15** + 0-5/10Vdc Vibration Output
- Pin 16** - 0-5/10Vdc Vibration Output

Notes:

- Pins 3 and 4 are tied together but are NOT tied to the grounding tab on the back of the enclosure.
- Land the accelerometer cable's shield on Pin 4.
- Tie Pin 3 to either din rail ground or Earth ground with the use of an external wire.

Typical Wiring Diagram

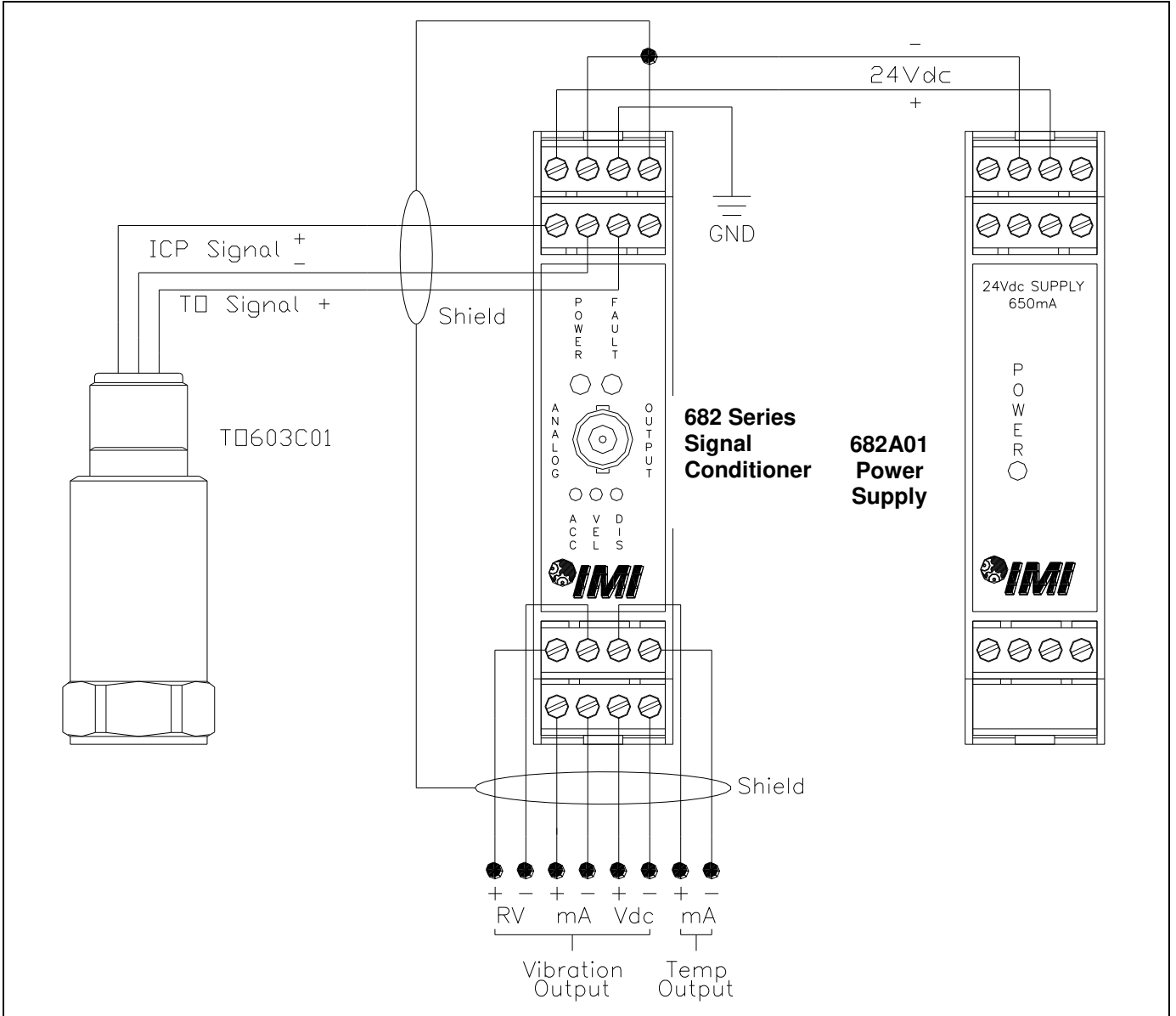

CE

To Maintain Conformance, Earth Ground, Power Supply Common, and I/O Shields must be connected together.

Note: If using the 682 Power Supply, mount the 682 Signal Conditioner to the left of the power supply with a recommended minimum separation distance of 4" where applicable.

Configuring the 682 Series

Internal PC Board Diagram

The Internal PC Board Diagram shows the location of the internal DIP Switch, Filter Modules, and Sensor Power Select Jumper. The DIP switch is used to configure the signal conditioner for various sensor and vibration ranges. The Filter Modules are installed to set the High and Low cutoff frequencies. The Jumper selects unregulated, regulated, or no ICP® power to the accelerometer.

The PC Board is accessible through the front of the indicator by removing the Screw Terminal Connectors and disengaging the tabs on the TOP and BOTTOM of the meter with a screwdriver. Once disengaged, the PC Board can be slid out for configuration.

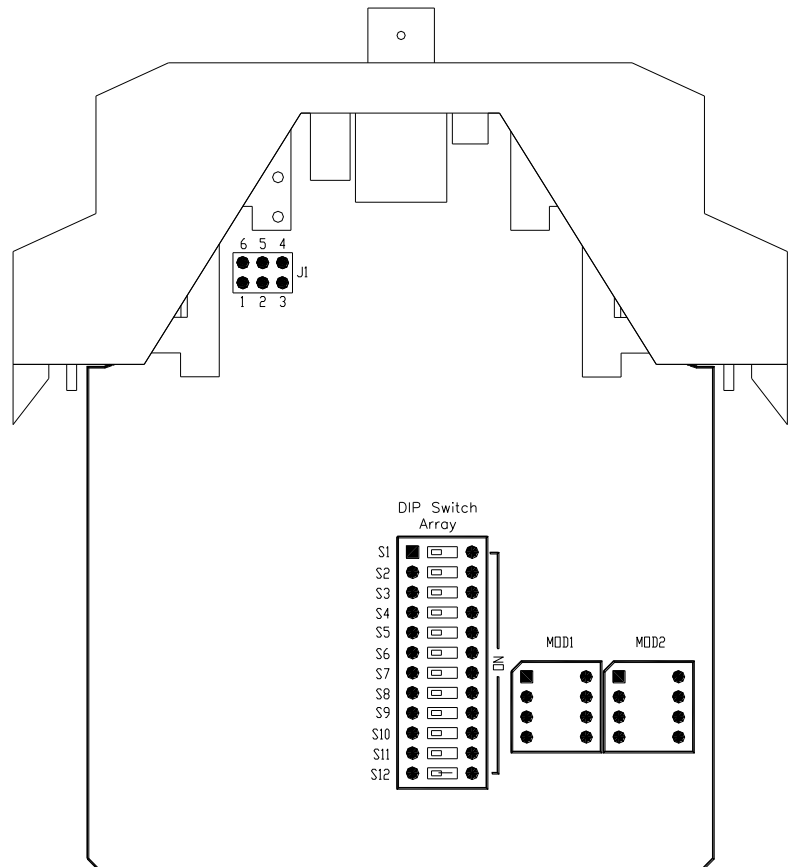

DIP Switch and Filter Module Descriptions:

- S1 and S2:** Acceleration Mode
- S3 and S4:** Velocity Mode
- S5 and S6:** Displacement Mode
- S7:** RMS
- S8:** Peak
- S9:** 20g, 2ips, 40mils

S10: 10g, 1ips, 20mils

S11: 5g, 0.5ips, 10mils

S12: Off = 0-5Vdc Output, On = 0-10Vdc Output

Internal DIP Switch Setting

The Internal DIP Switch of the 682 Series must be configured for the Full Scale Output of the ICP[®] Sensor connected to it. This is accomplished by removing the front cover and sliding the PC Board out of the Signal Conditioner. Once removed, the DIP switch should be configured per one of the conditions in the following table.

Range Setting	S1	S2	S3	S4	S5	S6	S7	S8	S9	S10	S11
5g RMS	ON	ON	OFF	OFF	OFF	OFF	ON	OFF	OFF	OFF	ON
5g Peak	ON	ON	OFF	OFF	OFF	OFF	OFF	ON	OFF	OFF	ON
10g RMS	ON	ON	OFF	OFF	OFF	OFF	ON	OFF	OFF	ON	OFF
10g Peak	ON	ON	OFF	OFF	OFF	OFF	OFF	ON	OFF	ON	OFF
20g RMS	ON	ON	OFF	OFF	OFF	OFF	ON	OFF	ON	OFF	OFF
20g Peak	ON	ON	OFF	OFF	OFF	OFF	OFF	ON	ON	OFF	OFF
0.5 in/sec RMS	OFF	OFF	ON	ON	OFF	OFF	ON	OFF	OFF	OFF	ON
0.5 in/sec Peak	OFF	OFF	ON	ON	OFF	OFF	OFF	ON	OFF	OFF	ON
1.0 in/sec RMS	OFF	OFF	ON	ON	OFF	OFF	ON	OFF	OFF	ON	OFF
1.0 in/sec Peak	OFF	OFF	ON	ON	OFF	OFF	OFF	ON	OFF	ON	OFF
2.0 in/sec RMS	OFF	OFF	ON	ON	OFF	OFF	ON	OFF	ON	OFF	OFF
2.0 in/sec Peak	OFF	OFF	ON	ON	OFF	OFF	OFF	ON	ON	OFF	OFF
10 mils p-p	OFF	OFF	OFF	OFF	ON	ON	OFF	OFF	OFF	OFF	ON
20 mils p-p	OFF	OFF	OFF	OFF	ON	ON	OFF	OFF	OFF	ON	OFF
40 mils p-p	OFF	OFF	OFF	OFF	ON	ON	OFF	OFF	ON	OFF	OFF

S12	OFF	0-5Vdc Output
S12	ON	0-10Vdc Output

Note: Factory Default Setting is 1.0in/sec Peak, 0-5Vdc Output

Filter Module Location

The Filter Modules are utilized to set the cutoff frequency of the internal band pass filter circuit. The 682 Series comes standard with Modules preinstalled. If a different cutoff frequency is desired, the preinstalled module can be removed by simply pulling it out of the MOD socket, and replacing it with a different module. The module is labeled with the type of filter, Low Pass or High Pass, and the cutoff frequency. Module location is as follows:

MOD1: Low Pass (LP) Filter Module Location
MOD2: High Pass (HP) Filter Module Location

Warning: Do not make any adjustments to the internal potentiometers. These potentiometers are used for factory calibration and adjusting them will require return of the 682 Series unit to the factory for recalibration.

Sensor Power Jumper Configuration:

Regulated 18Vdc/4mA Power

Jumper 2-5 and 3-4

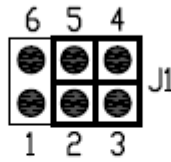

**Unregulated 24Vdc Supply/4mA Power
(Factory Default)**

Jumper 1-6 and 3-4

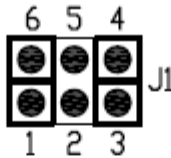

Note: If there is no DC bias on the input signal, this will trigger the Open/short detection which subtracts 4mA from output

**Sensor Power Disabled
(No ICP[®] Power to Accelerometer)**

Jumper 1-6 and 2-3

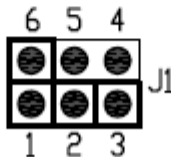

Warning 1 – ESD sensitivity

The power supply/signal conditioner should not be opened by anyone other than qualified service personnel. This product is intended for use by qualified personnel who recognize shock hazards and are familiar with the safety precautions required to avoid injury.

Warning 2 – ESD sensitivity

This equipment is designed with user safety in mind; however, the protection provided by the equipment may be impaired if the equipment is used in a manner not specified by PCB Piezotronics, Inc.

Caution 1 – ESD sensitivity

Cables can kill your equipment. High voltage electrostatic discharge (ESD) can damage electrical devices. Similar to a capacitor, a cable can hold a charge caused by triboelectric transfer, such as that which occurs in the following:

- *Laying on and moving across a rug,*
- *Any movement through air,*
- *The action of rolling out a cable, and/or*
- *Contact with a non-grounded person.*

The PCB solution for product safety:

- *Connect the cables only with the AC power off.*
- *Temporarily “short” the end of the cable before attaching it to any signal input or output.*

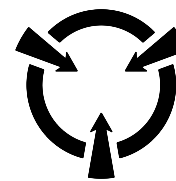

CAUTION
ELECTROSTATIC
DISCHARGE SENSITIVE

Caution 2 – ESD sensitivity

ESD considerations should be made prior to performing any internal adjustments on the equipment. Any piece of electronic equipment is vulnerable to ESD when opened for adjustments. Internal adjustments should therefore be done ONLY at an ESD-safe work area. Many products have ESD protection, but the level of protection may be exceeded by extremely high voltage.

Ordering Information

IMI Part Number: **682A X 3**

Frequency Response/Isolation*

0	3Hz to 10kHz (Standard)
1	3Hz to 1kHz
2	10Hz to 10kHz
3	10Hz to 1kHz
4	3Hz to 10kHz with 500Vdc I/O Isolation
5	3Hz to 1kHz with 500Vdc I/O Isolation
6	10Hz to 10kHz with 500Vdc I/O Isolation
7	10Hz to 1kHz with 500Vdc I/O Isolation

Ordering Example: 682B13

This is a 4-20mA Din Rail ICP® Signal Conditioner with the following:
 Frequency Response: 3Hz to 1kHz
 I/O Isolation: None

****Additional Options Available – Please Inquire***

Warranty

IMI instrumentation is warranted against defective material and workmanship for 1 year unless otherwise expressly specified. Damage to instruments caused by incorrect power or misapplication, is not covered by warranty. *If there are any questions regarding power, intended application, or general usage, please consult with your local sales contact or distributor.* Batteries and other expendable hardware items are not covered by warranty.

Service

Because of the sophisticated nature of IMI instrumentation, field repair is typically **NOT** recommended and may void any warranty. If factory service is required, return the instrumentation according to the "Return Procedure" stated below. *A repair and/or replacement quotation will be provided prior to servicing at no charge.* Before returning the unit, please consult a factory IMI applications engineer concerning the situation as certain problems can often be corrected with simple on-site procedures.

Return procedure

To expedite returned instrumentation, contact a factory IMI applications engineer for a RETURN MATERIAL AUTHORIZATION (RMA) NUMBER. Please have information available such as model and serial number. Also, to insure efficient service, provide a written description of the symptoms and problems with the equipment to a local sales representative or distributor, or contact IMI if none are located in your area.

Customers outside the U.S. should consult their local IMI distributor for information on returning equipment. For exceptions, please contact the International Sales department at IMI to request shipping instructions and an RMA. For assistance, please call (716) 684-0003, or fax us at (716) 684-3823. You may also receive assistance via e-mail at imi@pcb.com or visit our web site at www.pcb.com.



Customer Service

IMI, a division of PCB Piezotronics, guarantees **Total Customer Satisfaction**. If, at any time, for any reason, you are not completely satisfied with any IMI product, IMI will repair, replace, or exchange it at no charge. You may also choose, within the warranty period, to have your purchase price refunded.

IMI offers to all customers, at no charge, 24-hour phone support. This service makes product or application support available to our customers, day or night, seven days a week. When unforeseen problems or emergency situations arise, call the **IMI Hot Line at (716) 684-0003**, and an application specialist will assist you.



3425 Walden Avenue, Depew, NY 14043-2495
Phone: (716) 684-0003 • USA Fax: (716) 684-3823 • INTL Fax: (716) 684-4703

*ICP[®] is a registered trademark of PCB Group, Incorporated,
which uniquely identifies PCB sensors that incorporate built-in microelectronics.*

Model Number
682C03

ICP® VIBRATION TRANSMITTER

Revision: A
ECN #: 48518

Performance	ENGLISH	SI	
Channels	1	1	
Input Signal(Vibration)	± 100 mV/g	± 10.2 mV/(m/s ²)	[4]
Input Signal(Temperature)	0 to 1.2 VDC	0 to 1.2 VDC	[5]
Output Signal(DC Vibration)	4 to 20 mA	4 to 20 mA	[6]
Output Signal(DC Vibration)	0 to 5 VDC	0 to 5 VDC	[3][7]
Output Signal(DC Vibration)	0 to 10 VDC	0 to 10 VDC	[3][7]
Output Signal(Temperature)	4 to 20 mA	4 to 20 mA	[5]
Output Signal(± 0.01 %)(AC Vibration)	100 mV/g	10.2 mV/(m/s ²)	[8]
Frequency Range(-3 dB)(Acceleration)	180 to 600,000 cpm	3 to 10k Hz	[9][10][11]
Frequency Range(-3 dB)(Velocity)	210 to 600,000 cpm	3.5 to 10k Hz	[9][10][11]
Frequency Range(-3 dB)(Displacement)	210 to 60,000 cpm	3.5 to 1000 Hz	[9][12][10]
Output Range(DC Acceleration)	0 to 5.00 g pk or rms	0 to 49.03 m/s ² pk or rms	[3][13][4]
Output Range(DC Acceleration)	0 to 10.00 g pk or rms	0 to 98.06 m/s ² pk or rms	[3][13][4]
Output Range(DC Acceleration)	0 to 20.00 g pk or rms	0 to 196.12 m/s ² pk or rms	[3][13][4]
Output Range(DC Velocity)	0 to 0.5 in/sec pk or rms	0 to 12.7 mm/s pk or rms	[3][13][4]
Output Range(DC Velocity)	0 to 1.00 in/sec pk or rms	0 to 25.4 mm/s pk or rms	[3][13][4]
Output Range(DC Velocity)	0 to 2.00 in/sec pk or rms	0 to 50.8 mm/s pk or rms	[3][13][4]
Output Range(DC Displacement)	0 to 10.0 mil pk - pk	0 to 0.254 mm pk - pk	[3][13][4]
Output Range(DC Displacement)	0 to 20.0 mil pk - pk	0 to 0.508 mm pk - pk	[3][13][4]
Output Range(DC Displacement)	0 to 40.0 mil pk - pk	0 to 1.02 mm pk - pk	[3][13][4]
Environmental			
Temperature Range(Operating)	-13 to 158 °F	-25 to 70 °C	
Temperature Range(Storage)	-40 to 257 °F	-40 to 125 °C	
Humidity Range(Non-Condensing)	0 to 95 %	0 to 95 %	
Electrical			
Power Required	DC Power	DC Power	
DC Power	23 to 25 VDC	23 to 25 VDC	
DC Power(maximum)	100 mA	100 mA	
Settling Time	<2 min	<2 min	
Excitation Voltage(delivered to sensor)	17 to 19 VDC	17 to 19 VDC	[1][2]
Constant Current Excitation(delivered to sensor)	3 to 5 mA	3 to 5 mA	[1][2]
Output Span(± 5.0 %)(DC Vibration Current Output)	16 mA	16 mA	
Output Span(± 5.0 %)(Temperature Output)	16 mA	16 mA	
Output Span(± 5.0 %)(DC Vibration Voltage Output)	5 or 10 VDC	5 or 10 VDC	[3]
Physical			
Electrical Connector(input/output)	Removable Screw Terminals	Removable Screw Terminals	
Electrical Connector(raw vibration output)	BNC Jack	BNC Jack	
Housing Material	Polyamide	Polyamide	
Size (Height x Width x Depth)	3.9 in x 0.9 in x 4.5 in	99 mm x 22.5 mm x 114.5 mm	
Weight(Maximum)	6.4 oz	127	
Screw Terminal Wire Size	24-14 AWG	24-14 AWG	
Din Rail Mount	1.38 in	35 mm	
Status Indicator(Power "on")	Green LED	Green LED	
Status Indicator(Input Fault)	Red LED	Red LED	
Status Indicator(Measurement Mode - Acceleration)	Green LED	Green LED	
Status Indicator(Measurement Mode - Velocity)	Green LED	Green LED	
Status Indicator(Measurement Mode - Displacement)	Green LED	Green LED	

OPTIONAL VERSIONS

Optional versions have identical specifications and accessories as listed for the standard model except where noted below. More than one option may be used.

NOTES:

- [1] Jumper selectable for 18 VDC regulated, 24 VDC power supply voltage or ICP® sensor excitation disabled
- [2] 4 mA constant current diode is internal to 9330VT
- [3] Internal Dip switch selectable
- [4] Output measurement range is based upon input from 100 mV/g ICP® accelerometer and will be scaled inversely proportional to any percentage deviation of this input.
- [5] Requires use of accelerometer with "TO" temperature output option.
- [6] Output current voltage will fluctuate at frequencies below 5 Hz.
- [7] Factory set, 0-5 VDC.
- [8] Achieved with 100 mV/g ICP® accelerometer input.
- [9] Attenuation is -40 dB/decade.
- [10] The low frequency tolerance is accurate within ± 0.5 Hz of the specified frequency.
- [11] The high frequency tolerance is accurate within ± 0.5 kHz of the specified frequency.
- [12] Maximum 1,000 Hz for displacement.
- [13] Factory set, 1.0 in/sec peak
- [14] See PCB Declaration of Conformance PS152 for details.

Entered: LK	Engineer: gs	Sales: MPN	Approved: BAM	Spec Number:
Date: 8/2/2018	Date: 8/2/2018	Date: 8/2/2018	Date: 8/2/2018	67464



All specifications are at room temperature unless otherwise specified.
In the interest of constant product improvement, we reserve the right to change specifications without notice.

ICP® is a registered trademark of PCB Group, Inc.

IMI SENSORS
A PCB PIEZOTRONICS DIV.
3425 Walden Avenue, Depew, NY 14043

Phone: 800-959-4464
Fax: 716-684-3823
E-Mail: imi@pcb.com

40537

PCB Piezotronics Inc. claims proprietary rights in the information disclosed hereon. Neither it nor any reproduction thereof will be disclosed to others without the written consent of PCB Piezotronics Inc.

REVISIONS		
REV	DESCRIPTION	DIN
B	DIM .44 WAS .50	45450

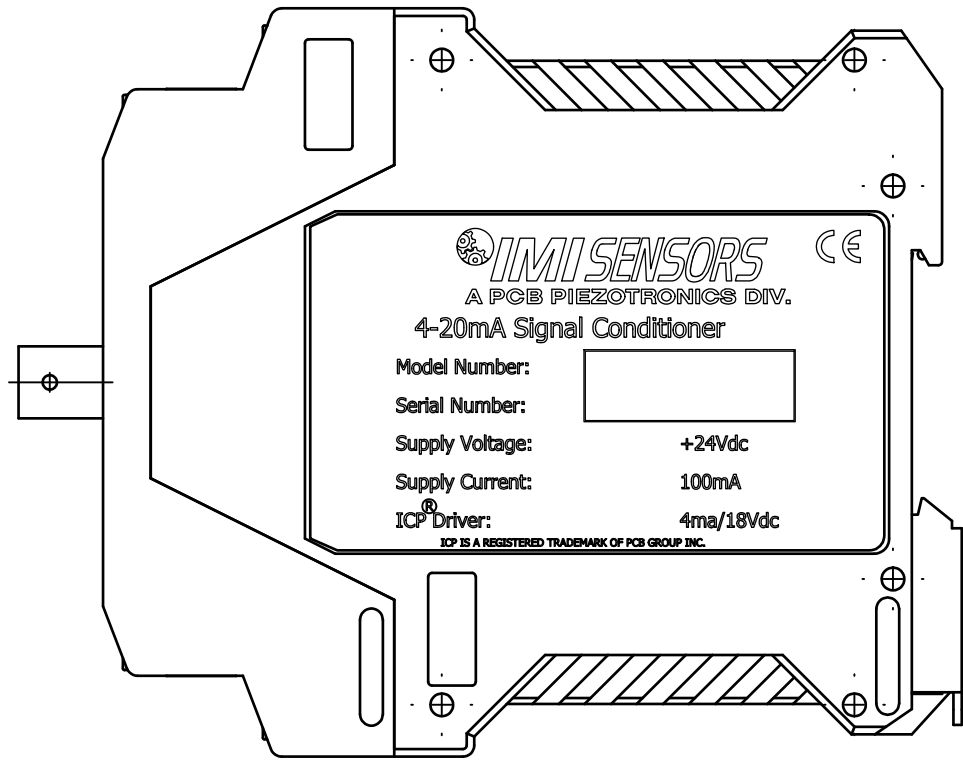
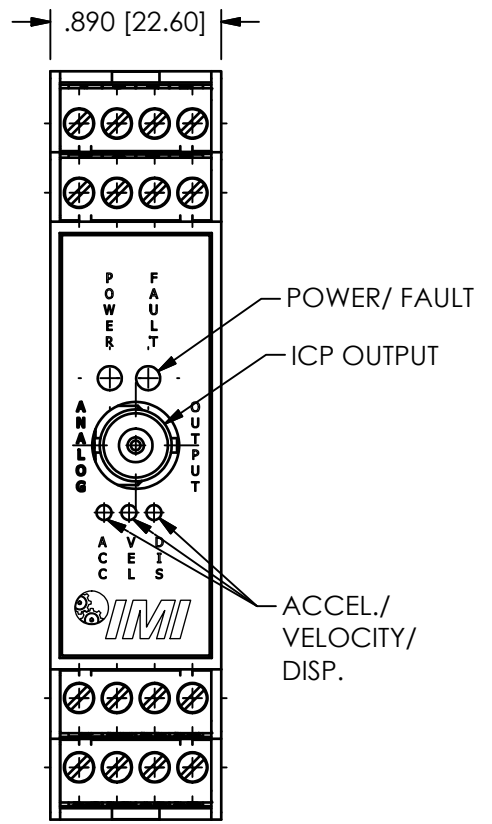
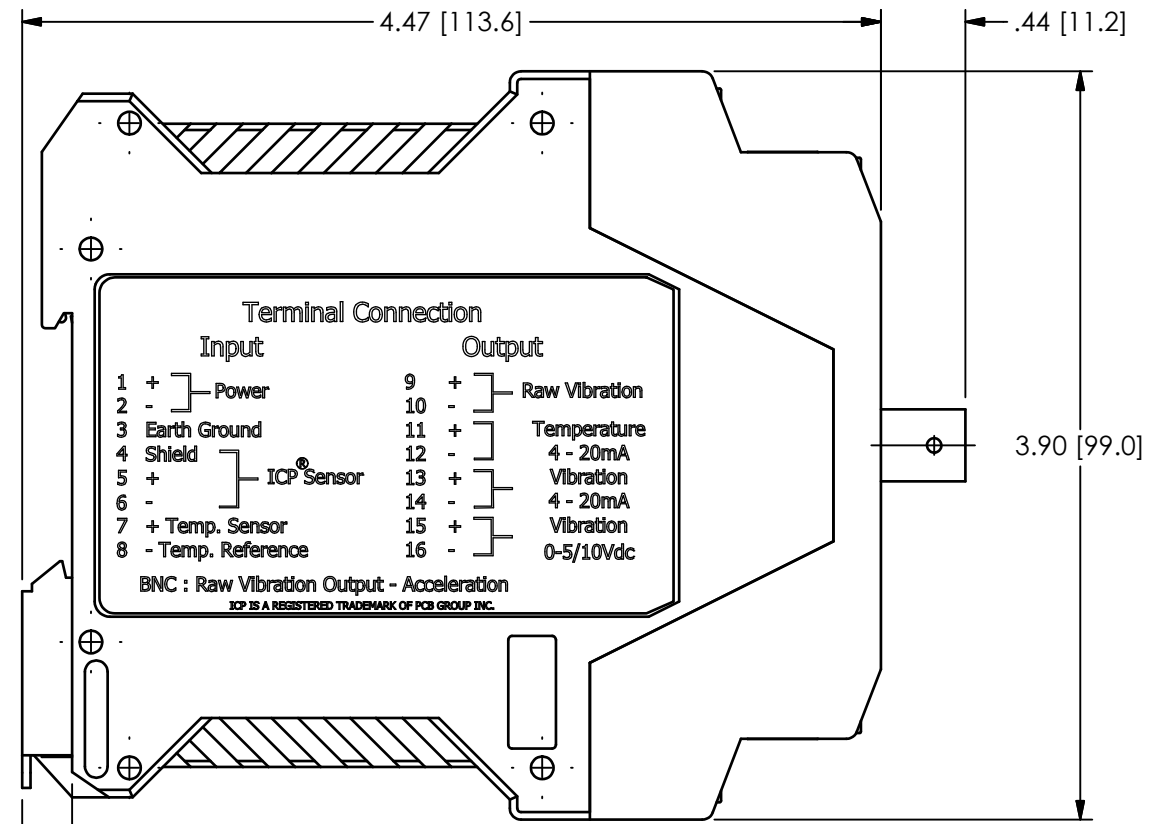

.260 [6.60]

UNLESS OTHERWISE SPECIFIED TOLERANCES ARE:		DRAWN		CHECKED		ENGINEER		
DIMENSIONS IN INCHES	DIMENSIONS IN MILLIMETERS [IN BRACKETS]	JDM	5/31/16	ECB	5/31/16	CPH	5/31/16	
DECIMALS XX ±.03 XXX ±.010	DECIMALS X ±0.8 XX ±0.25	TITLE OUTLINE DRAWING 4-20 DIN RAIL CONDITIONER						3425 WALDEN AVE. DEPEW, NY 14043 (716) 684-0001 E-MAIL: sales@pcb.com
ANGLES ± 2 DEGREES	ANGLES ± 2 DEGREES							CODE IDENT. NO. 52681
FILLETS AND RADII .003 - .005	FILLETS AND RADII 0.07 - 0.13	SCALE: FULL		SHEET 1 OF 1				

PCB PIEZOTRONICS